

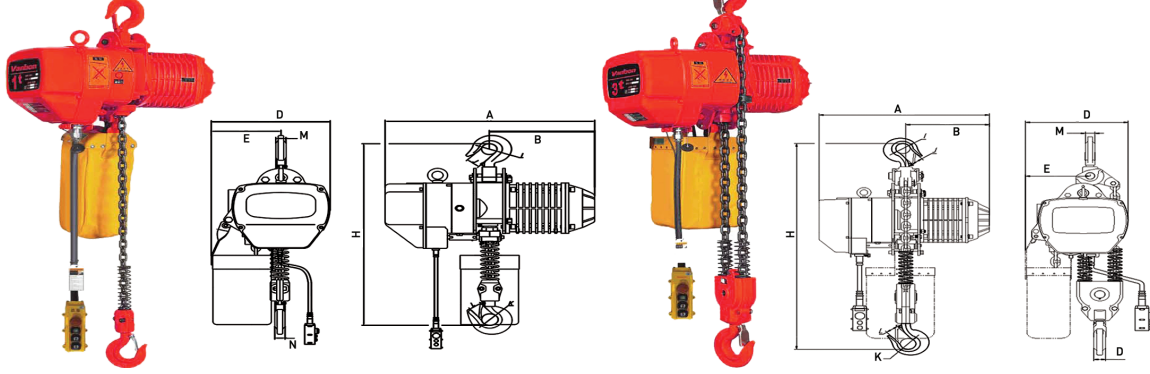

ELEKTRİKLİ ZİNCİRLİ VİNÇ ELECTRICAL CHAIN HOISTS

KANCA ASKILI / HOOK FIXED

500 kg. - 5 ton



TEKNİK PARAMETRELER (TEK HIZLI) / TECHNICAL PARAMETERS (SINGLE SPEED)

| MODEL TYPE | KAPASİTE CAPACITY | KALDIRMA HIZI LIFTING SPEED (m/min.) | GÜÇ POWER | DEVİR/DAK. ROTATION SPEED | ENERJİ FAZ PHASES | VOLTAJ VOLTAGE | HZ | DONAM CHAIN FALL | ZİNCİR ÖLÇÜSÜ CHAIN SPECIFICATION | TEST YÜKÜ TEST LOAD | AĞIRLIK WEIGHT | EXTRA MT WEIGHT ADDED WITH 1M. HIGHER |
|-------------|-------------------|--------------------------------------|-----------|---------------------------|-------------------|----------------|-------|------------------|-----------------------------------|---------------------|----------------|---------------------------------------|
| WBH-00501SF | 0.5 | 6.8 | 0.75 | 1440 | 3 | 200-460 | 50/60 | 1 | Φ 6.3 | 0.625 | 47 | 0.81 |
| WBH-01001SF | 1 | 6.6 | 1.5 | 1440 | 3 | 200-460 | 50/60 | 1 | Φ 7.1 | 1.25 | 61 | 1.1 |
| WBH-01002SF | 1 | 3.4 | 0.75 | 1440 | 3 | 200-460 | 50/60 | 2 | Φ 6.3 | 1.25 | 52 | 1.62 |
| WBH-02001SF | 2 | 6.6 | 3.0 | 1440 | 3 | 200-460 | 50/60 | 1 | Φ 10.0 | 2.5 | 115 | 2.3 |
| WBH-02002SF | 2 | 3.3 | 1.5 | 1440 | 3 | 200-460 | 50/60 | 2 | Φ 7.1 | 2.5 | 73 | 2.2 |
| WBH-03001SF | 3 | 5.4 | 3.0 | 1440 | 3 | 200-460 | 50/60 | 1 | Φ 11.2 | 3.75 | 122 | 2.8 |
| WBH-03002SF | 3 | 4.4 | 3.0 | 1440 | 3 | 200-460 | 50/60 | 2 | Φ 10.0 | 3.75 | 131 | 4.7 |
| WBH-05002SF | 5 | 2.7 | 3.0 | 1440 | 3 | 200-460 | 50/60 | 2 | Φ 11.2 | 6.25 | 151 | 5.6 |

TEKNİK PARAMETRELER (ÇİFT HIZLI) / TECHNICAL PARAMETERS (DUAL SPEED)

| MODEL TYPE | KAPASİTE CAPACITY | KALDIRMA HIZI LIFTING SPEED (m/min.) | KALDIRMA MOTORU LIFTING MOTOR | | ENERJİ FAZ PHASES | VOLTAJ VOLTAGE | HZ | DONAM CHAIN FALL | ZİNCİR ÖLÇÜSÜ CHAIN SPECIFICATION | TEST YÜKÜ TEST LOAD | AĞIRLIK WEIGHT | EXTRA MT WEIGHT ADDED WITH 1M. HIGHER |
|-------------|-------------------|--------------------------------------|-------------------------------|---------------------------|-------------------|----------------|-------|------------------|-----------------------------------|---------------------|----------------|---------------------------------------|
| | | | GÜÇ POWER | DEVİR/DAK. ROTATION SPEED | | | | | | | | |
| WBH-00501DF | 0.5 | 6.9/2.3 | 0.80/27 | 2890/980 | 3 | 200-460 | 50/60 | 1 | Φ 6.3 | 0.625 | 47 | 0.81 |
| WBH-01001DF | 1 | 6.9/2.3 | 1.8/0.6 | 2890/980 | 3 | 200-460 | 50/60 | 1 | Φ 7.1 | 1.25 | 61 | 1.1 |
| WBH-01002DF | 1 | 3.5/1.2 | 0.8/0.27 | 2890/980 | 3 | 200-460 | 50/60 | 2 | Φ 6.3 | 1.25 | 52 | 1.62 |
| WBH-02001DF | 2 | 6.8/2.3 | 3.0/1.0 | 2890/980 | 3 | 200-460 | 50/60 | 1 | Φ 10.0 | 2.5 | 115 | 2.3 |
| WBH-02002DF | 2 | 3.3/1.1 | 1.8/0.6 | 2890/980 | 3 | 200-460 | 50/60 | 2 | Φ 7.1 | 2.5 | 73 | 2.2 |
| WBH-03001DF | 3 | 5.4/1.8 | 3.0/1.0 | 2890/980 | 3 | 200-460 | 50/60 | 1 | Φ 11.2 | 3.75 | 122 | 2.8 |
| WBH-03001SF | 3 | 4.5/1.5 | 3.0/1.0 | 2890/980 | 3 | 200-460 | 50/60 | 1 | Φ 10.0 | 3.75 | 131 | 4.7 |
| WBH-05002DF | 5 | 2.7/0.9 | 3.0/1.0 | 2890/980 | 3 | 200-460 | 50/60 | 2 | Φ 11.2 | 6.25 | 151 | 5.6 |

ÖLÇÜ BİLGİLERİ (TEK HIZLI) / SIZE SPECIFICATION (SINGLE SPEED)

| MODEL TYPE | H | A | B | D | E | I | J | K | L | M | N |
|-------------|------|-----|-----|-----|-----|------|----|------|----|----|----|
| WBH-00501SF | 550 | 460 | 230 | 280 | 160 | Φ 35 | 25 | Φ 35 | 25 | 17 | 17 |
| WBH-01001SF | 650 | 520 | 260 | 300 | 176 | Φ 40 | 31 | Φ 40 | 31 | 22 | 22 |
| WBH-01002SF | 670 | 460 | 230 | 280 | 205 | Φ 40 | 31 | Φ 40 | 31 | 22 | 22 |
| WBH-02001SF | 800 | 615 | 295 | 430 | 265 | Φ 47 | 40 | Φ 47 | 38 | 30 | 30 |
| WBH-02002SF | 835 | 520 | 260 | 300 | 236 | Φ 47 | 38 | Φ 47 | 38 | 30 | 30 |
| WBH-03001SF | 845 | 615 | 295 | 430 | 265 | Φ 58 | 47 | Φ 58 | 47 | 36 | 36 |
| WBH-03002SF | 950 | 615 | 295 | 430 | 320 | Φ 58 | 47 | Φ 58 | 47 | 36 | 36 |
| WBH-05002SF | 1030 | 615 | 295 | 430 | 325 | Φ 60 | 48 | Φ 60 | 48 | 43 | 43 |

ÖLÇÜ BİLGİLERİ (ÇİFT HIZLI) / SIZE SPECIFICATION (DUAL SPEED)

| MODEL TYPE | H | A | B | D | E | I | J | K | L | M | N |
|-------------|------|-----|-----|-----|-----|------|----|------|----|----|----|
| WBH-00501DF | 550 | 545 | 260 | 280 | 160 | Φ 35 | 28 | Φ 35 | 25 | 17 | 17 |
| WBH-01001DF | 650 | 582 | 280 | 300 | 176 | Φ 40 | 31 | Φ 40 | 31 | 22 | 22 |
| WBH-01002DF | 670 | 545 | 260 | 280 | 205 | Φ 40 | 31 | Φ 40 | 31 | 22 | 22 |
| WBH-02001DF | 800 | 670 | 313 | 430 | 265 | Φ 47 | 40 | Φ 47 | 38 | 30 | 30 |
| WBH-02002DF | 835 | 582 | 280 | 300 | 236 | Φ 47 | 38 | Φ 47 | 38 | 30 | 30 |
| WBH-03001DF | 845 | 670 | 313 | 430 | 265 | Φ 58 | 47 | Φ 58 | 47 | 36 | 36 |
| WBH-03002DF | 950 | 670 | 313 | 430 | 320 | Φ 58 | 47 | Φ 58 | 47 | 36 | 36 |
| WBH-05002DF | 1030 | 670 | 313 | 430 | 325 | Φ 60 | 48 | Φ 60 | 48 | 43 | 43 |